

## WARRANTY

All fiber optic transmission systems, products and accessories manufactured by Liteway, Inc. and its subsidiaries are fully tested prior to shipment and are warranted against defective materials and workmanship for a period of two full years from the date of the original shipment. Should a problem occur, a Return Material Authorization Number (RMA) must be obtained from Liteway Inc. at (516) 931-2800 and the item returned to Liteway, Inc. 166 Haverford Road, Hicksville, NY 11801, USA, prepaid. Liteway Inc. will then, at its option repair or replace the defective item.

Liteway, Inc. maximum liability under this warranty is limited to the cost of the defective item only. No contingent liabilities of any kind are either assumed or implied.

Any items returned to Liteway, Inc. that have been misused, abused, damaged, modified, connected or adjusted in any way contrary to the instructions furnished by Liteway, Inc. or repaired by unauthorized personnel will not be covered by this warranty. Any non-warranty repairs required will be quoted at the current rate for such services.



### Important Notices



#### **CAUTION! AVOID DIRECT EXPOSURE TO BEAM.**

All -7,-8, and -9 Models use laser diodes. These solid-state laser diodes are located in the optical ports of these units. Laser diodes produce invisible radiation that may be harmful to human eyes. Never look directly into the optical port of any fiber optic unit designed to operate with single-mode optical fiber.

#### **NOT FOR LIFE SUPPORT SYSTEMS**

Liteway, Inc. does not authorize or warrant any of its products or accessories for use in critical life support systems or applications of any kind.

## OPERATING INSTRUCTIONS

### Fiber Optic IRIG Signal Distribution

### IRGM-1504 & IRGP-1501



The IRGM-1504 is an optical transmitter that converts an electrical IRIG A through E input signal into four individual optical output signals for distribution over separate fiber optic cables to IRGR-1501 receivers.

The IRGP-1501 is an optical repeater that is used to implement a drop-and-repeat linear IRIG A through E distribution networks.

#### Technical Specifications

Signal Bandwidth	20 Hz to 500 KHz
In/Out Impedance	50 ohms
In/Out Signal Level	3 volt peak to peak, (5 mA)
Signal/Noise Ratio	60 dB/min (ref 1Vpp)
Linearity & THD	3% max
Operating Wavelength	850 (-1), 1300 (-3,-7), 1550 (-9)
Optical Output	-15 dBm typical
Optical Loss Budget	0 – 12 dB
Fibers Accommodated	1 Multimode (-1,-3), 1 Single-mode (-7,-9)
MTBF	100,000 Hours (MIL-HDBK-217D)
Temperature Range	-35° to +75°C
Power Requirements	11-24 VAC/DC @500 mA
Physical Size (mm)	5.0"(127)L x 1.0" (25.4)W x 7.0"(178)D

All specifications measured with 1Km of 62.5u multimode fiber.

All specifications are subject to change without prior notice.

# Installation Instructions

The diagram below shows the typical installation IRIG system that uses the IRGM-1504 and IRGP-1501 for IRIG distribution.

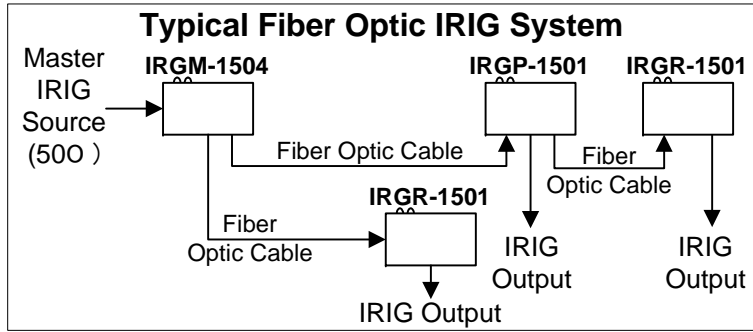

In the above diagram only two optical outputs are utilized. The IRGM-1504 provides four optical outputs. Multiple IRGM-1504 units may be "daisy-chained" when more than 4 output channels are required.

## Adjustment of the IRGP-1501

The IRGP-1501 IRIG repeater has a fiber optic receiver that can be adjusted to compensate for the unique fiber losses of your installation. The range of the receiver level control is adequate to allow the full 0 - 13dB optical path loss range to be accommodated. The receiver **Level** adjustment **must** be set for a 3-volt peak to peak IRIG output signal for proper operation of the IRIG repeater.

## Power Terminal Block Connections

Pin	Function
1	Alarm output for use with optional Alarm Sensing Unit ALM-1000. <b>No other connections should be made to this terminal</b>
2	+11 to 24 DC or AC Volts input
3	AC or DC return (Common to Housing)

Be certain to check all connections, settings and voltages before applying power

## Indicator Lights

Indicator	Lights when
Pwr	Proper power is present.
Alrm	The loss of signal alarm is activated and there is no IRIG signal present to transmit.
Sig	A data signal is being received.

The **Alarm** switch is used to turn the alarm function on and off.